



Wall valve 1/2" -

35 607 970 90



- red brass, lead-free
- female thread 1/2" connection
- 1x female thread 1/2" outlet
- dust cover
- anti-water packing
- soundproofing
- suitable for xGRID (when using installation track + 12 mm recess depth)

Required miscellaneous

Leak protection 1/2" -

12 010 970 90



Wall valve 1/2" -

35 607 970 90

mm [inches]

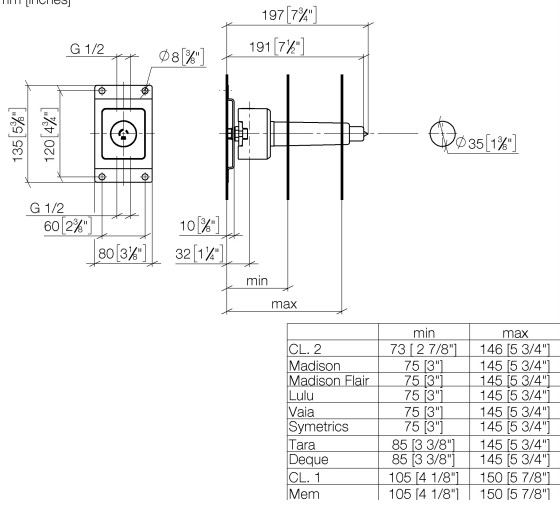

Flow rate chart

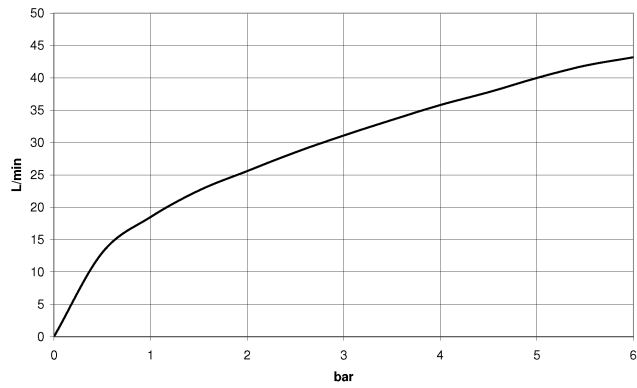

Certificates

DVGW_DW-
6501DN0116.

WRAS_2010066.

Wall valve 1/2" -

35 607 970 90

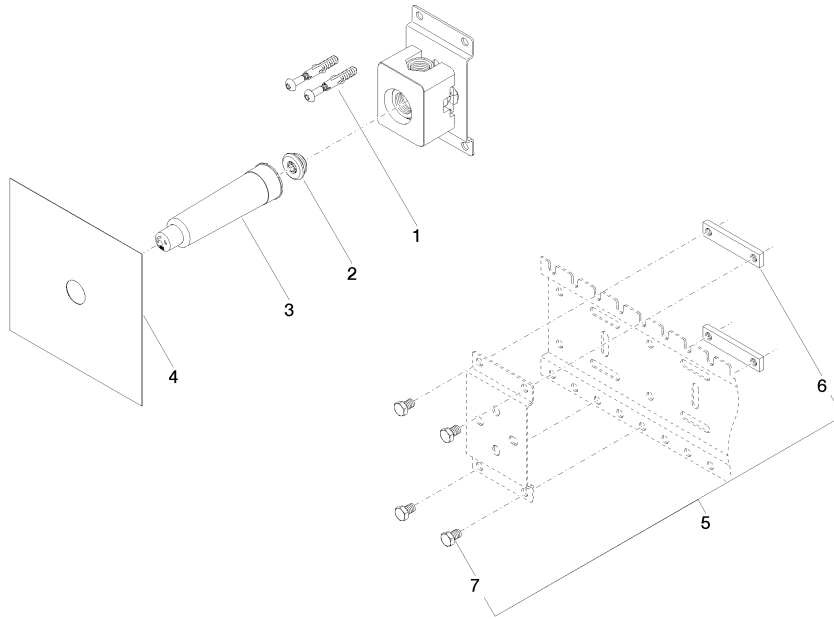

Spare parts list

No.	Item Number	Name	Quantity used	Delivery time
1	04 30 31 024 01 90	fixing set	2	2
2	04 31 20 006 00 90	plug	1	2
3	09 21 02 173 90	cap	1	2
4	04 14 03 072 01 90	gasket kit	1	2
5	04 17 20 100 00 90	fixing set	1	2
6	09 17 20 100 90	holder	2	2
7	09 30 30 152 90	screw	4	2